



Component Heaters (Optional)

Section 06-05

Komatsu has made every effort to make this manual as accurate as possible based on the information available at the time of publication and printing. Continuous improvement and advancement of product design may cause changes to machines, which may not have been included in this publication. Komatsu reserves the right to make changes and improvements at any time. To ensure the most current information, please contact your service center.

Table of Contents

Safety	3
Safety, Warnings and Cautions	3
Theory of Operation	5
Component Description	7
Component Heater Connection Box.....	7
Battery Warmer System (optional).....	7
Hydraulic Reservoir Heaters (optional).....	7
Grease Reservoir Heater (optional).....	7
Engine Coolant and Oil Preheater System (optional).....	7
Fuel Preheating System (optional)	8
Circuit Description	9
Component Heater Connection Box.....	9
Battery Warmer System (optional).....	10
Hydraulic Reservoir Heaters (optional).....	10
Grease Reservoir Heater (optional).....	11
Engine Coolant and Oil Preheater System (optional).....	11
System Operation	11
Operation of the Engine Coolant Preheater	11
Maintenance of the Engine Coolant Preheater.....	13
Safety Preparations	13
Operation of the Engine Oil Preheater	16
Maintenance of the Engine Oil Preheater	16
Replacement of the Flow-Through Thermostat	17
Safety Preparations	17
Replacement of Oil Heating Element.....	20
Safety Preparations	20
Replacement of Lube Sensing Unit (if so equipped)	23
Safety Preparations	23
Settings and Adjustments	27
Hydraulic Reservoir Heater Setting	27
Safety Preparations	27
Battery Warmer Setting	30
Grease Reservoir Heater Setting.....	31
Engine Coolant and Oil Preheater System.....	31
Troubleshooting	33

Table of Figures

Figure 1.	Component heater connection box (typical).....	6
Figure 2.	Component heater connection box.....	9
Figure 3.	Hydraulic reservoir heaters (typical).....	10
Figure 4.	Grease reservoir heater (thermostat called out).....	11
Figure 5.	Engine coolant and oil preheater (typical system).....	12
Figure 6.	Frame Lock.....	13
Figure 7.	Battery Isolation Box – Battery isolation switch in OFF position with locks in place	14
Figure 8.	Hydraulic reservoir air valve handle UP	14
Figure 9.	Open air reservoir bleed valves	15
Figure 10.	Pressure bleed down valves.....	15
Figure 11.	Hydraulic reservoir air valve handle UP	18
Figure 12.	Hydraulic reservoir heater control (shown with cap removed for clarity).....	30
Figure 13.	Grease reservoir heater (thermostat called out).....	31

Safety

This publication contains special instructions that pertain to safety, operation, maintenance, and repair of the machine. Listed below are the signal words and symbols that precede these instructions and their meanings:

DANGER

- The danger label indicates a hazardous situation which, if not avoided, will result in death or serious injury.

WARNING

- The warning label indicates a hazardous situation which, if not avoided, could result in death or serious injury.

CAUTION

- The caution label, used with the safety alert symbol indicates a hazardous situation which, if not avoided, could result in minor or moderate injury (includes the safety alert symbol .

CAUTION

- The caution label (without safety alert symbol) is used to address practices not related to personal injury, only equipment damage.

NOTICE

The NOTICE graphic is to indicate areas of importance to the reader that are not related to personal injury or machine damage.

Safety, Warnings and Cautions

WARNING

CRUSH HAZARD

- Crush hazards exist if the machine is started or moved while work processes are being performed on the machine. Place bucket flat and level on the ground. Place frame lock in the locked position and lock out the machine's starting capability before performing any work process. Follow all applicable lockout procedures and local rules and regulations for performing work processes. ANYONE performing inspections or service procedures to the machine should be familiar with ALL instructions and procedures contained in the machine's SERVICE MANUAL. Crush hazard could occur if the machine is started or moves while any type of work process is being conducted on the machine, resulting in serious injury or death.
- Crush hazards exist in machine pivot area and area between the tires. Do not enter these areas unless it is verified that the operator has control over the steering and that personnel locking the frame lock have good communication with the operator. Entering the pivot area and area between the tires while the machine is moving or pivoting (articulating) could cause crush hazards resulting in serious injury or death.
- Crush hazards exist if all personnel are not cleared from the bucket and lift arm area before using the hydraulic hoist and bucket hydraulic pressure bleed down valves to relieve pressure from the

hoist and bucket circuit. Assembly must be used only when the engine is NOT running. Before using the Manual Bleed Valve Assembly, refer to “HYDRAULIC AND GREASE SYSTEMS”, “MANUAL BLEED VALVE ASSEMBLY”, in Section 04 of the Service Manual for additional operational and safety information. Operating the manual bleed valve may cause the lift arms and bucket to descend rapidly. All personnel around the bucket and lift arms area shall be removed from the area before operating hydraulic hoist and bucket hydraulic pressure bleed down valves. Using the hydraulic bleed down valves could result in movement of the lift arms and bucket which could cause a crush hazard resulting serious injury or death.

CRUSH, SHOCK, OR OTHER HAZARDS

- Crush, shock, or other hazards exist if stored energy is not removed or isolated prior to working on the machine. Stored energy (hydraulic, electrical, pneumatic, mechanical, etc.) may be present if not isolated or released prior to working on the machine. Do not work on the machine without removing this stored energy (suspended loads, electrical power, air pressure, etc.). Risk of crushing, shock, or other physical injury exists if stored energy is not removed or isolated prior to working on the machine which could result in serious injury or death.

ELECTRICAL SHOCK HAZARD

- Electrical shock hazard exists when working on component heaters. Some heaters may operate as high as 240 volts. Heaters should never be worked on, replaced, or repaired unless they are disconnected from the power source and disabled from operation. Electrical shock is possible. Failure to disconnect equipment before working on it can cause electrical shock hazards resulting in serious injury or death.

EYE INJURY HAZARD

- Eye injury hazard exists when working around batteries. Batteries contain acid that can cause blindness if eye exposure occurs. ALWAYS wear appropriate personal protective equipment (PPE) such as long sleeves, safety goggles or a face shield when working around batteries. Wear locally required PPE. Refer to Section 02 in the Service Manual, “24 VDC SYSTEM” for additional information concerning battery maintenance and safety. Failure to wear appropriate PPE can cause eye injury hazards resulting in serious injury.



BURN HAZARD

- Burn hazard exists when working around battery heaters. Battery heater elements become hot and can cause burns. DO NOT touch them when the system is in operation, or when it is cooling down. Failure to avoid battery heaters when hot or cooling down can cause burn hazards resulting in injury.

Theory of Operation

Various components may require heating for protection against freezing temperatures or condensation during times when the machine is shutdown in cold weather. **Heaters are optional and may not be present on machines unless installation was requested.**

CAUTION

NEVER run the engine while the engine heating system is operating. The flow check valve prevents coolant flow through the pre-heater while the engine is running. The heating element will be damaged if plugged in while the engine is running.

CAUTION

Bleed the engine cooling system at the highest point to eliminate air locks. The reason for bleeding the lines is to ensure the heating element is surrounded by coolant at all times. Lack of coolant around the heating element will destroy it.

CAUTION

Coolant mixtures that contain excessive amounts of antifreeze may also damage some heating elements.



CAUTION

Burn hazard exists when working around battery heaters. Battery heater elements become hot and can cause burns. DO NOT touch them when the system is in operation, or when it is cooling down. Failure to avoid battery heaters when hot or cooling down can cause burn hazards resulting in injury.

Heaters for the following components only operate on external power (power supply external to the machine). They DO NOT operate when the machine is not connected to external power.

- Battery Warmers
- Hydraulic Reservoir
- Grease Reservoir
- Engine Coolant
- Engine Oil
- Fuel Preheater

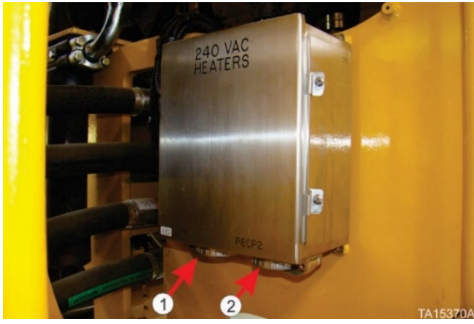

Left side of machine at pivot area
typical mounting location

1. Component heater receptacle (240V)

- Hydraulic tank heater(s)
- Battery heater
- Grease reservoir heater

2. Engine cold weather start (240V)

- Engine oil heater connection*
- Engine coolant heater connection*

***Right and Left**

3. Fuses

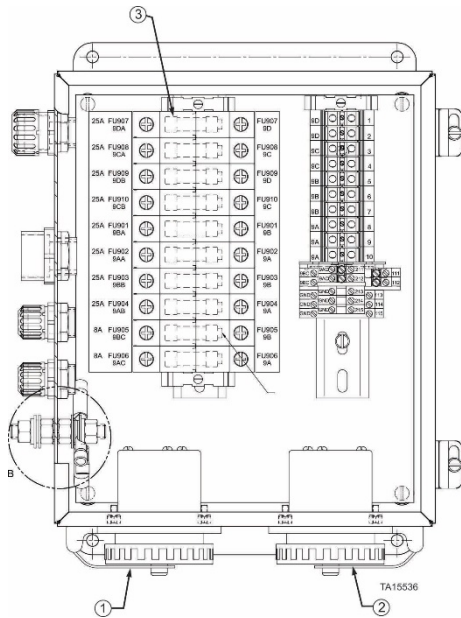

NOTICE

Items listed are optional

Figure 1. Component heater connection box (typical)

Component Description

Component Heater Connection Box

A stainless steel box is mounted in the articulation area of the machine typically on the left side of the machine. It has external connectors for attaching external power to the machine, to power various component heaters.

Battery Warmer System (optional)

The battery warmer consists of a pair of vulcanized rubber mats with embedded heating elements. The mats are located underneath the batteries. The battery warmers are only powered by external power. They are 120-volt warmers, rated at 75-watts, connected in series to operate on 240-volts. Two pairs may be installed and connected in parallel.

Hydraulic Reservoir Heaters (optional)

The heaters are installed into the side of the hydraulic reservoir. Two 240-volt, 4000-watt immersion heaters are used for heating the hydraulic oil. The heaters are in a sealed moisture resistant housing, and are thermostatically controlled.

Grease Reservoir Heater (optional)

A 240-volt, 1000-watt, thermostatically controlled heater is available to warm the grease in the reservoir when the machine is parked during cold weather. The heater typically measures 9.5" W X 62.8" L (some reservoirs use heaters with different dimensions). The heater is held in position around the grease reservoir with a hook and spring closure. The heater must be in full contact with the reservoir and below the level of grease while in operation.

CAUTION

The grease reservoir heater must not be clamped in dented areas of the reservoir.

Do NOT bend the grease reservoir heater sharply as this may cause internal damage to the heating element.

CAUTION

The grease reservoir has a vent that must remain clear of obstructions, to allow for expansion of material inside the reservoir when heating. Equipment damage is possible if the vent is allowed to become inoperable.

Engine Coolant and Oil Preheater System (optional)

The engine pre-heater operates on 240V and is wired for external power only. Power is supplied through the component heater connections at the pivot area on the left side of the machine. The heater system consists of an engine coolant and lubricating oil heater that is controlled by a single thermostat.

Fuel Preheating System (optional)

The fuel preheating system uses coolant heated by the engine coolant pre-heater to heat the fuel. The fuel preheating system, like the engine coolant preheating system, operates only on externally supplied power while the machine is parked. Power is supplied to the fuel preheating system through the component heater connections at the pivot area on the left side of the machine.

Circuit Description

There are external connectors to connect the various component heaters. When the machine is connected to the external connectors, there are two sets of combined connections.

Component Heater Connection Box

A stainless steel box is mounted in the articulation area of the machine typically on the left side of the machine. It has external connectors for attaching external power to the machine, to power various component heaters. Wiring information is found on the Electrical Schematic in the Parts Manual for each machine model so equipped.

One external connector powers the:

- Grease Reservoir heater
- Hydraulic Reservoir heater
- Battery warmer

The other external connector powers the:

- Engine Coolant heater
- Engine Oil heater

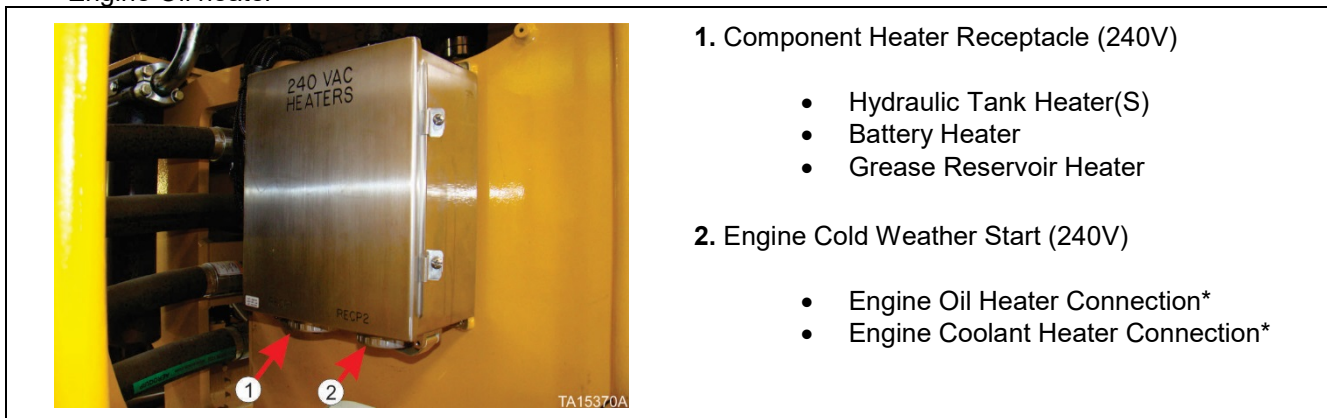

1. Component Heater Receptacle (240V)

- Hydraulic Tank Heater(S)
- Battery Heater
- Grease Reservoir Heater

2. Engine Cold Weather Start (240V)

- Engine Oil Heater Connection*
- Engine Coolant Heater Connection*

Figure 2. Component heater connection box

Battery Warmer System (optional)

The batteries are warmed by the heating elements in the mats. The battery warmer provides better starting capabilities in cold weather by maintaining the machine's batteries at a temperature that allows optimum cranking power and charging, and it prevents freezing of the electrolyte. The heaters are powered by connecting 240V commercial power to the Component Heater Connection Box.

The battery heaters receive external power through a single exterior mounted receptacle located on the left side of the machine at the pivot area. They are powered by connecting 240V external power to the heater receptacle. They are not thermostatically controlled and should not be left connected during hot weather.

The battery warmers maintenance includes:

- A periodic inspection of the electrical connections for areas of wear or damage
 - Verify that they are properly functioning.
- Inspection for areas of wear on the mats

The normal charging function of the batteries, during operation of the machine, will typically keep the batteries warm enough to prevent cold weather damage.

WARNING

Eye injury hazard exists when working around batteries. Batteries contain acid that can cause blindness if eye exposure occurs. ALWAYS wear appropriate personal protective equipment (PPE) such as long sleeves, safety goggles or a face shield when working around batteries. Wear locally required PPE. Refer to Section 02 in the Service Manual, "24 VDC SYSTEM" for additional information concerning battery maintenance and safety. Failure to wear appropriate PPE can cause eye injury hazards resulting in serious injury.

Replacement parts are available through Komatsu. Refer to the Parts Manual to order replacement parts.

Hydraulic Reservoir Heaters (optional)

The heaters are operated ONLY on external power (when the machine is so connected). They are powered by connecting 240V commercial power to the Component Heater Connection Box.



Figure 3. Hydraulic reservoir heaters (typical)

Grease Reservoir Heater (optional)

The heater only operates on external power. It is controlled by a thermostat control that is directly attached to the heater. It is powered by connecting 240V commercial power to the Component Heater Connection Box.

CAUTION

Do NOT bend the grease reservoir heater sharply as this may cause internal damage to the heating element.

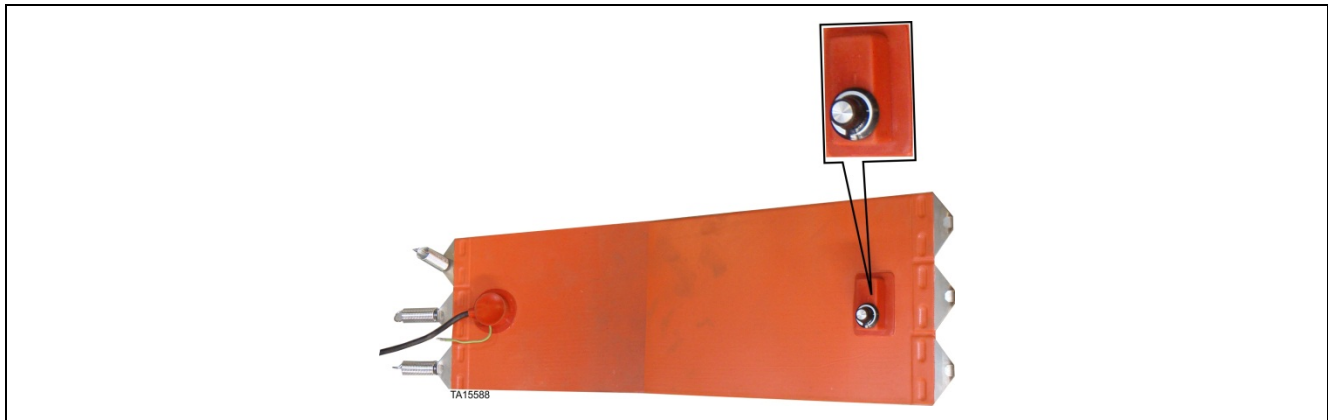

Figure 4. Grease reservoir heater (thermostat called out)

Engine Coolant and Oil Preheater System (optional)

The engine coolant and oil pre-heater system provides better engine starting capabilities in cold weather by preheating the coolant and lubricating oil. It is powered by connecting 240V commercial power to the Component Heater Connection Box.

System Operation

The engine heating system consists of an engine coolant and lubricating oil heater. These heaters are controlled by a single internal thermostat. The engine heating system is wired for external power only. It receives power through an external connection located in the articulation area of the machine.

Operation of the Engine Coolant Preheater

The engine coolant and oil preheater system operates on the principle of a thermo-siphon. Heated coolant expands and forces the flow check valve on the inlet closed. The heated coolant is forced up into the outlet to the top of the engine. When the pressure drops in the reservoir, cold coolant enters and the cycle is repeated. A flow-through thermostat installed in the inlet line of the engine pre-heater measures the coolant at its coldest point and keeps the coolant within the preset temperature range.

CAUTION

NEVER run the engine while the engine heating system is operating. The flow check valve prevents coolant flow through the pre-heater while the engine is running. The heating element will be damaged if plugged in while the engine is running.

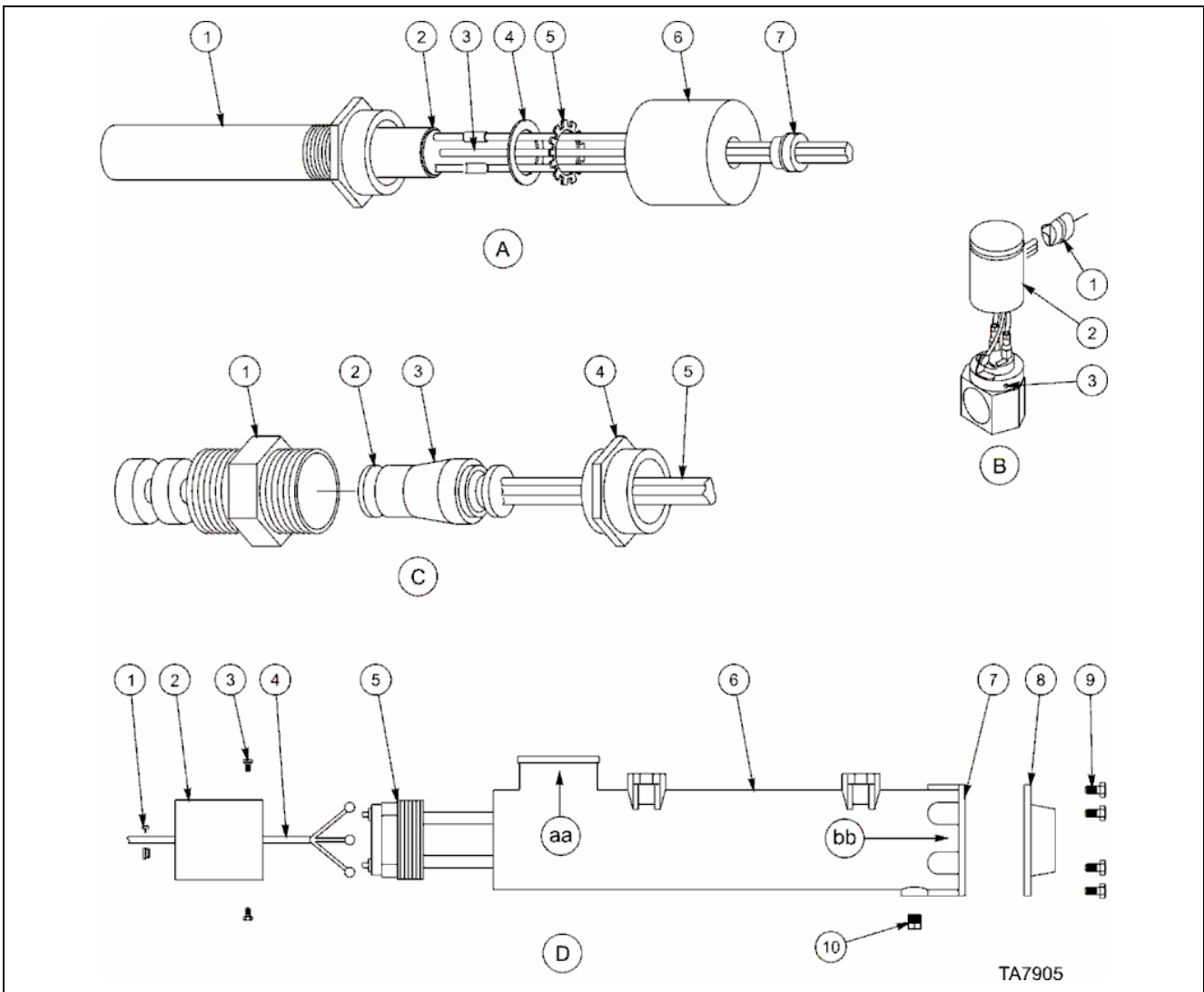

- | | |
|---|--|
| <p>A. Engine Oil Heater
 A1. Well
 A2. Element
 A3. Gnd. wire
 A4. Washer
 A5. Retaining ring
 A6. Cap
 A7. Strain relief</p> <p>B. Flow-thru thermostat
 B1. Strain relief
 B2. Cap
 B3. Set screws</p> <p>C. Lube sensing unit
 C1. Well
 C2. Sensing unit</p> | <p>C3. Plug
 C4. Hex cap
 C5. Cord</p> <p>D. Engine coolant preheater
 D1. Strain relief
 D2. Cover cap
 D3. Phillips screw (2)
 D4. Cord
 D5. Element assembly
 D6. Tank
 D7. See note 1 below
 D8. Head & valve
 D9. Hex head capscrews (4)
 D10. Drain plug</p> |
|---|--|

NOTE 1: Use permatex blue silicone form-a-gasket

Figure 5. Engine coolant and oil preheater (typical system)

Maintenance of the Engine Coolant Preheater

The following maintenance operations should be performed to obtain long-term service from the unit:

Periodically check the hoses and replace if necessary.

Perform the following maintenance ANNUALLY or every 2000 engine operating hours, whichever occurs first:

Safety Preparations

WARNING

Crush hazards exist if the machine is started or moved while work processes are being performed on the machine. Place bucket flat and level on the ground. Place frame lock in the locked position and lock out the machine's starting capability before performing any work process. Follow all applicable lockout procedures and local rules and regulations for performing work processes. ANYONE performing inspections or service procedures to the machine should be familiar with ALL instructions and procedures contained in the machine's SERVICE MANUAL. Crush hazard could occur if the machine is started or moves while any type of work process is being conducted on the machine, resulting in serious injury or death.

- a. Stop the wheel loader on flat level ground.
- b. Set bucket flat and level on the ground.
- c. Move the frame lock to the locked position so that the frame cannot be steered.
- d. Place wheel chocks in front and behind each wheel.

WARNING

Crush hazards exist in machine pivot area and area between the tires. Do not enter these areas unless it is verified that the operator has control over the steering and that personnel locking the frame lock have good communication with the operator. Entering the pivot area and area between the tires while the machine is moving or pivoting (articulating) could cause crush hazards resulting in serious injury or death.

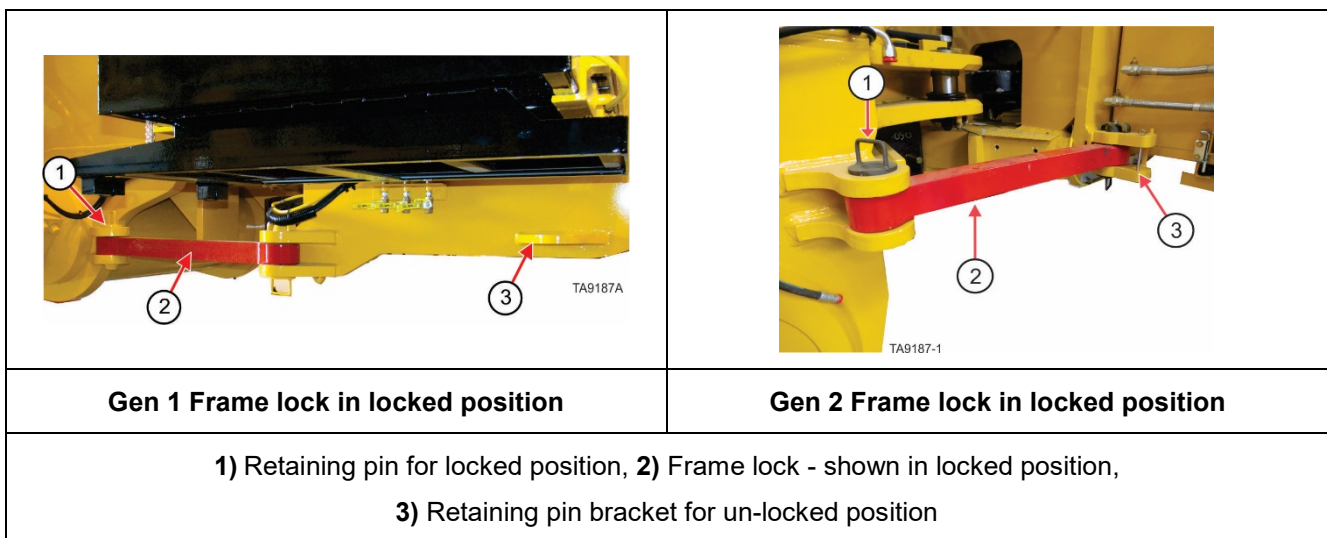

Figure 6. Frame Lock

- e. Set the parking brakes.

- f. Shut off the engine.

⚠ WARNING

Crush, shock, or other hazards exist if stored energy is not removed or isolated prior to working on the machine. Stored energy (hydraulic, electrical, pneumatic, mechanical, etc.) may be present if not isolated or released prior to working on the machine. Do not work on the machine without removing this stored energy (suspended loads, electrical power, air pressure, etc.). Risk of crushing, shock, or other physical injury exists if stored energy is not removed or isolated prior to working on the machine which could result in serious injury or death.

- g. Turn the battery and engine isolation switches to the off position and install locks on the battery isolation switch.



Figure 7. Battery Isolation Box – Battery isolation switch in OFF position with locks in place

- h. Release the air from the hydraulic reservoir by using the hydraulic reservoir air valve (ball valve) on top of the reservoir. The supply line from main air system will be blocked and reservoir air will vent out the hose that runs down the outside of the hydraulic reservoir.
- Turn the handle to the up position as shown

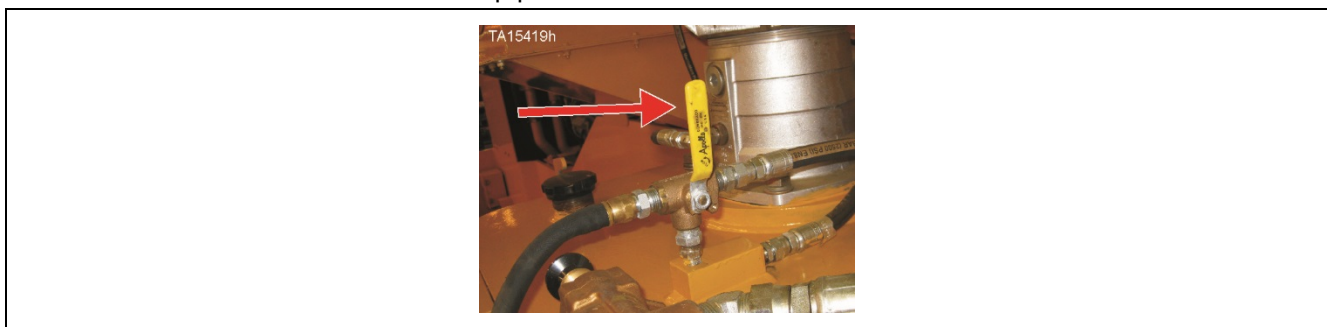

Figure 8. Hydraulic reservoir air valve handle UP

- i. Release the air from the various air storage reservoirs by opening all of the air bleed valves.

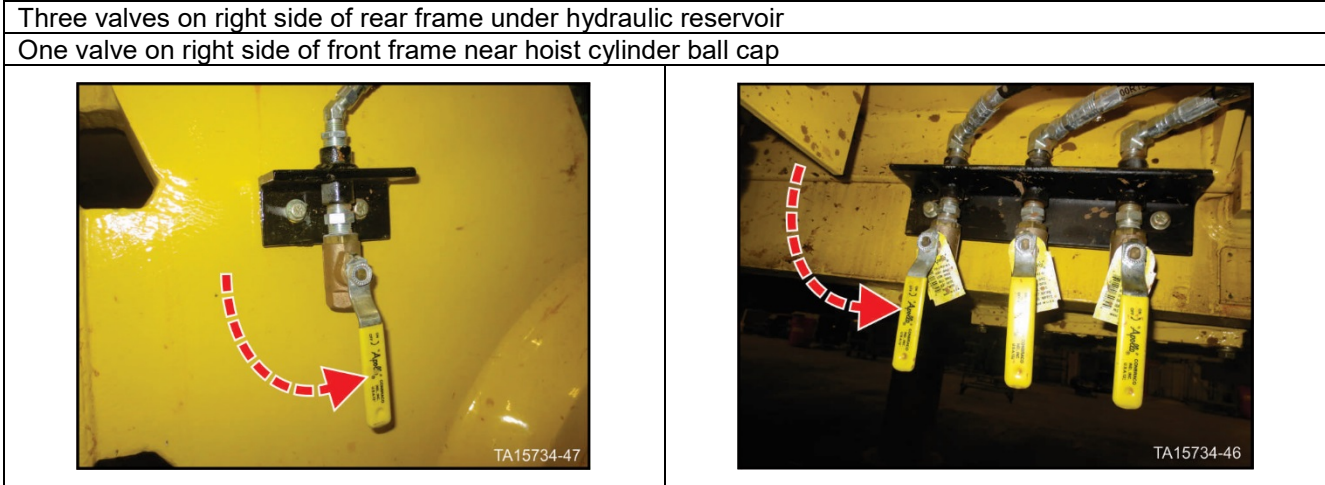

Figure 9. Open air reservoir bleed valves

 **WARNING**

Crush hazards exist if all personnel are not cleared from the bucket and lift arm area before using the hydraulic hoist and bucket hydraulic pressure bleed down valves to relieve pressure from the hoist and bucket circuit. Assembly must be used only when the engine is NOT running. Before using the Manual Bleed Valve Assembly, refer to “HYDRAULIC AND GREASE SYSTEMS”, “MANUAL BLEED VALVE ASSEMBLY”, in Section 04 of the Service Manual for additional operational and safety information. Operating the manual bleed valve may cause the lift arms and bucket to descend rapidly. All personnel around the bucket and lift arms area shall be removed from the area before operating hydraulic hoist and bucket hydraulic pressure bleed down valves. Using the hydraulic bleed down valves could result in movement of the lift arms and bucket which could cause a crush hazard resulting serious injury or death.

- j. Use the hydraulic pressure bleed down valves located in the front frame underneath the Husco valves to bleed any stored pressure in the hoist and bucket cylinders.
- k. Turn each valve slowly counterclockwise as shown below and allow the pressure to bleed down.
 - Open the valve completely and leave it open during this procedure.

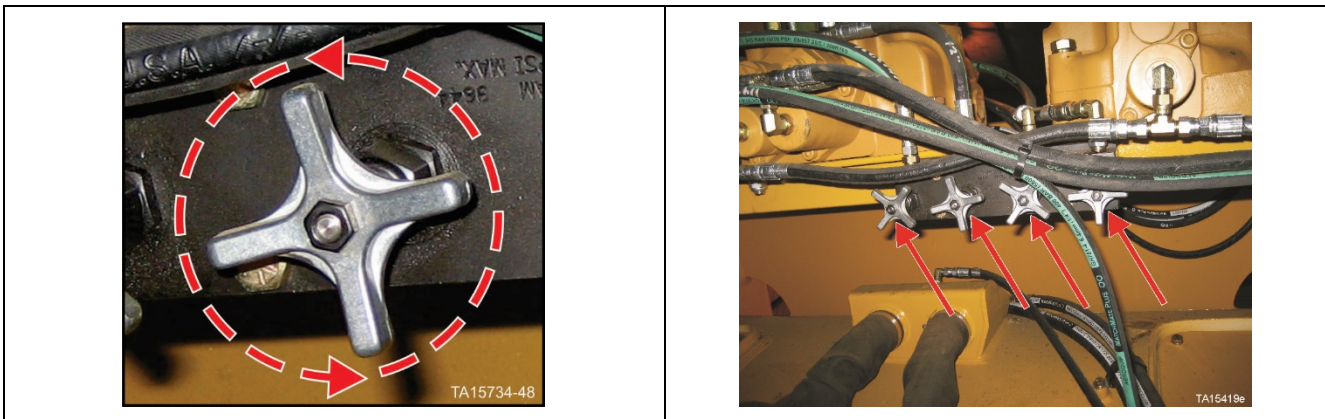

Figure 10. Pressure bleed down valves

- l. Remove cap and electrical wiring, inspect for wear or damage.

- m. Remove the engine coolant pre-heater and clean out accumulation of alkali and sludge. Clean the scale from the copper element with a wire brush. Clean out the tank.
- n. Inspect flange O-ring for damage. Valve should move freely. Aggressive solvents may harm O-ring.
- o. Replace any damaged or worn out parts with original parts. Replacement parts are available through Komatsu; refer to the Parts Manual for parts ordering information.
- p. Reassemble pre-heater with lubricant on threads and PERMATEX Blue Silicone Form-A-Gasket on the tank and flange. Reinstall properly.
- q. With the pre-heater outlet line disconnected at the engine, refill the engine until the outlet line is full of coolant. This eliminates airlocks in the pre-heater and hoses. Connect outlet line to engine and finish filling engine.
- r. Run the engine; check for coolant circulation and fill to proper level. Check for leaks, shut off engine, and let it cool.
- s. When the engine is cool, connect the engine pre-heater electrical wiring.
- t. Feel the outlet hose at the engine connection. It should get hot.

NOTICE

THE PREHEATER WILL NOT CIRCULATE COOLANT WITH AIRLOCKS IN THE HOSES. If the pre-heater tank is hot and the top of the outlet is not hot, unplug the heater. Disconnect and bleed the outlet line at the engine.

CAUTION

Bleed the engine cooling system at the highest point to eliminate air locks. The reason for bleeding the lines is to ensure the heating element is surrounded by coolant at all times. Lack of coolant around the heating element will destroy it.

Coolant mixtures containing excessive amounts of antifreeze may also damage the heating element.

- u. Once the cooling system has been bled of entrapped air (if necessary), let the engine cool. Plug in the pre-heater. Wait a few minutes and feel a temperature increase in the block and inlet hose. They should be warm or hot.
- v. Follow all lockout tag out rules, local rules, and local regulations to return the machine back to service.

Operation of the Engine Oil Preheater

The engine oil pre-heater is a cartridge-heating element in an aluminum well. It is installed in the side of the oil pan where it will be immersed in oil. Its operation is controlled by the lube oil thermostat or by the flow-through thermostat depending on how the system is installed. The engine oil pre-heater is wired to receive its power through the engine coolant pre-heater. The engine oil pre-heater operates on 240V and 300 watts.

Maintenance of the Engine Oil Preheater

The engine oil pre-heater and sensing unit, (if so equipped), require no maintenance other than to periodically check wiring connections and verify the system is operational. All parts are replaceable. Replacement parts are available through Komatsu; refer to the Parts Manual for parts ordering information.

Replacement of the Flow-Through Thermostat

The following procedures should be performed to replace the flow-through thermostat:

Safety Preparations

WARNING

Crush hazards exist if the machine is started or moved while work processes are being performed on the machine. Place bucket flat and level on the ground. Place frame lock in the locked position and lock out the machine's starting capability before performing any work process. Follow all applicable lockout procedures and local rules and regulations for performing work processes. ANYONE performing inspections or service procedures to the machine should be familiar with ALL instructions and procedures contained in the machine's SERVICE MANUAL. Crush hazard could occur if the machine is started or moves while any type of work process is being conducted on the machine, resulting in serious injury or death.

- a. Stop the wheel loader on flat level ground.
- b. Set bucket flat and level on the ground.
- c. Move the frame lock to the locked position so that the frame cannot be steered.
- d. Place wheel chocks in front and behind each wheel.

WARNING

Crush hazards exist in machine pivot area and area between the tires. Do not enter these areas unless it is verified that the operator has control over the steering and that personnel locking the frame lock have good communication with the operator. Entering the pivot area and area between the tires while the machine is moving or pivoting (articulating) could cause crush hazards resulting in serious injury or death.

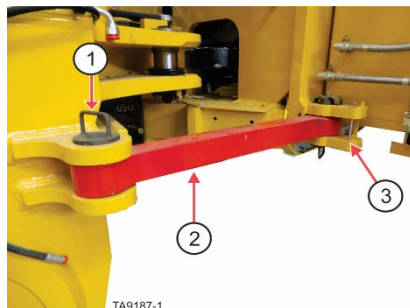

- 1) Retaining pin for locked position, 2) Frame lock - shown in locked position,
- 3) Retaining pin bracket for un-locked position

Frame lock in locked position

- e. Set the parking brakes.
- f. Shut off the engine.

⚠ WARNING

Crush, shock, or other hazards exist if stored energy is not removed or isolated prior to working on the machine. Stored energy (hydraulic, electrical, pneumatic, mechanical, etc.) may be present if not isolated or released prior to working on the machine. Do not work on the machine without removing this stored energy (suspended loads, electrical power, air pressure, etc.). Risk of crushing, shock, or other physical injury exists if stored energy is not removed or isolated prior to working on the machine which could result in serious injury or death.

- g. Turn the battery and engine isolation switches to the off position and install locks on the battery isolation switch.



Battery Isolation Box – Battery isolation switch in OFF position with locks in place

- h. Release the air from the hydraulic reservoir by using the hydraulic reservoir air valve (ball valve) on top of the reservoir. The supply line from main air system will be blocked and reservoir air will vent out the hose that runs down the outside of the hydraulic reservoir.
 - Turn the handle to the up position as shown

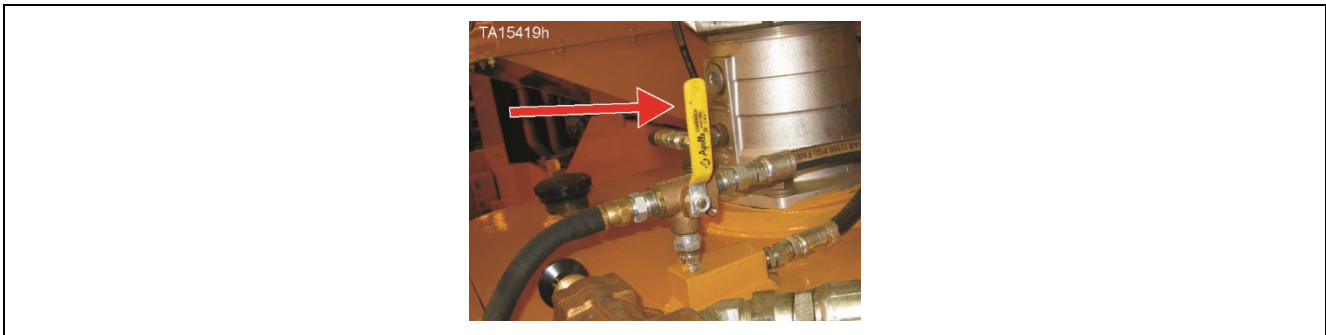
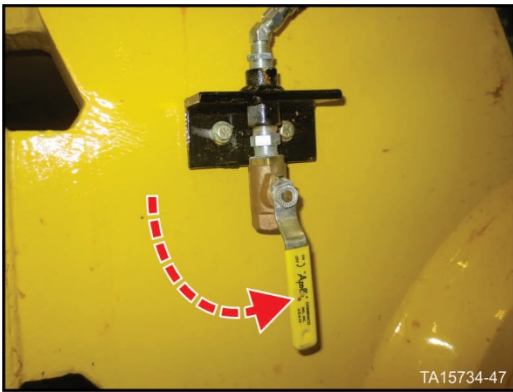

Figure 11. Hydraulic reservoir air valve handle UP

- i. Release the air from the various air storage reservoirs by opening all of the air bleed valves.

Three valves on right side of rear frame under hydraulic reservoir
 One valve on right side of front frame near hoist cylinder ball cap



Open air reservoir bleed valves

⚠ WARNING

Crush hazards exist if all personnel are not cleared from the bucket and lift arm area before using the hydraulic hoist and bucket hydraulic pressure bleed down valves to relieve pressure from the hoist and bucket circuit. Assembly must be used only when the engine is NOT running. Before using the Manual Bleed Valve Assembly, refer to “HYDRAULIC AND GREASE SYSTEMS”, “MANUAL BLEED VALVE ASSEMBLY”, in Section 04 of the Service Manual for additional operational and safety information. Operating the manual bleed valve may cause the lift arms and bucket to descend rapidly. All personnel around the bucket and lift arms area shall be removed from the area before operating hydraulic hoist and bucket hydraulic pressure bleed down valves. Using the hydraulic bleed down valves could result in movement of the lift arms and bucket which could cause a crush hazard resulting serious injury or death.

- j. Use the hydraulic pressure bleed down valves located in the front frame underneath the Husco valves to bleed any stored pressure in the hoist and bucket cylinders.
- k. Turn each valve slowly counterclockwise as shown below and allow the pressure to bleed down.
 - Open the valve completely and leave it open during this procedure.

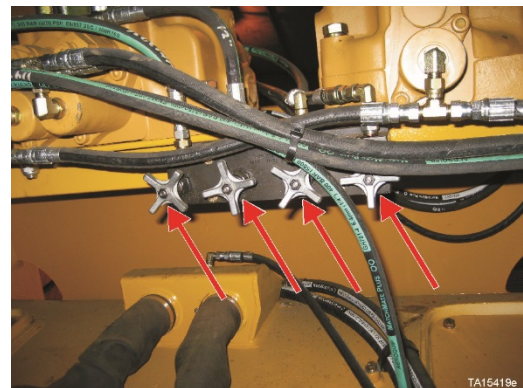
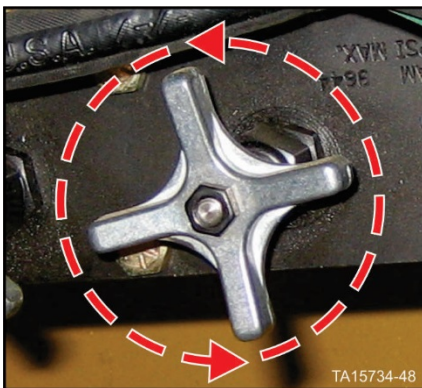

Pressure bleed down valves

- l. Disconnect the power supply to the thermostat.

- m. Remove the cord strain relief and cap.
- n. Disconnect the spade terminals from the sensing unit.
- o. Loosen the setscrews holding the sensing unit. Install new unit and tighten the setscrews.
- p. Connect the spade terminals, check the ground and reassemble the flow-through thermostat.
- q. Plug in the pre-heater and test for one complete cycle; i.e., pre-heater on-off-on.

NOTICE

The sensing unit is not in direct contact with the coolant and can be changed without draining the cooling system.

- r. Follow all lockout tag out rules, local rules, and local regulations to return the machine back to service.

Replacement of Oil Heating Element

Safety Preparations

WARNING

Crush hazards exist if the machine is started or moved while work processes are being performed on the machine. Place bucket flat and level on the ground. Place frame lock in the locked position and lock out the machine's starting capability before performing any work process. Follow all applicable lockout procedures and local rules and regulations for performing work processes. ANYONE performing inspections or service procedures to the machine should be familiar with ALL instructions and procedures contained in the machine's SERVICE MANUAL. Crush hazard could occur if the machine is started or moves while any type of work process is being conducted on the machine, resulting in serious injury or death.

- a. Stop the wheel loader on flat level ground.
- b. Set bucket flat and level on the ground.
- c. Move the frame lock to the locked position so that the frame cannot be steered.
- d. Place wheel chocks in front and behind each wheel.

WARNING

Crush hazards exist in machine pivot area and area between the tires. Do not enter these areas unless it is verified that the operator has control over the steering and that personnel locking the frame lock have good communication with the operator. Entering the pivot area and area between the tires while the machine is moving or pivoting (articulating) could cause crush hazards resulting in serious injury or death.

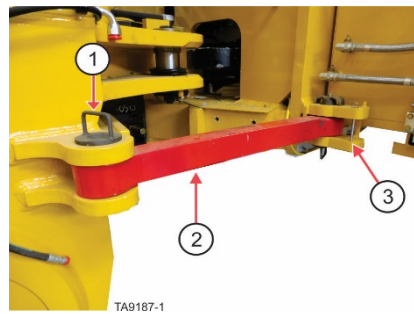

- 1) Retaining pin for locked position, 2) Frame lock - shown in locked position,
- 3) Retaining pin bracket for un-locked position

Frame lock in locked position

- e. Set the parking brakes.
- f. Shut off the engine.

⚠ WARNING

Crush, shock, or other hazards exist if stored energy is not removed or isolated prior to working on the machine. Stored energy (hydraulic, electrical, pneumatic, mechanical, etc.) may be present if not isolated or released prior to working on the machine. Do not work on the machine without removing this stored energy (suspended loads, electrical power, air pressure, etc.). Risk of crushing, shock, or other physical injury exists if stored energy is not removed or isolated prior to working on the machine which could result in serious injury or death.

- g. Turn the battery and engine isolation switches to the off position and install locks on the battery isolation switch.

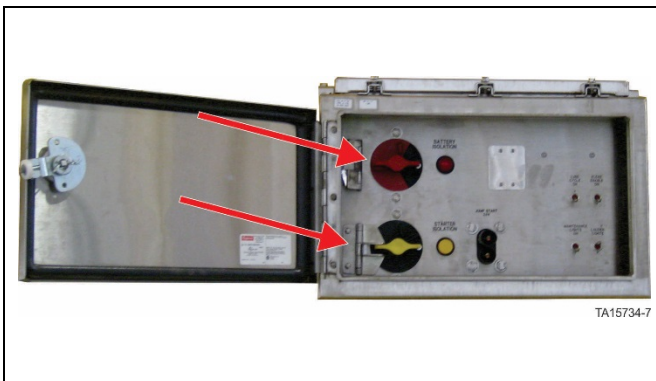

Battery Isolation Box – Battery isolation switch in OFF position with locks in place

- h. Release the air from the hydraulic reservoir by using the hydraulic reservoir air valve (ball valve) on top of the reservoir. The supply line from main air system will be blocked and reservoir air will vent out the hose that runs down the outside of the hydraulic reservoir.
 - Turn the handle to the up position as shown

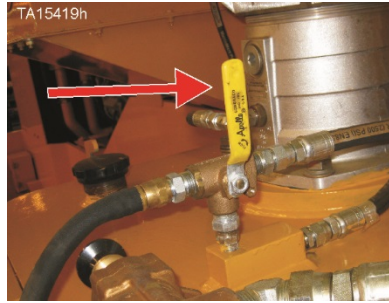

Hydraulic reservoir air valve handle UP

- i. Release the air from the various air storage reservoirs by opening all of the air bleed valves.

Three valves on right side of rear frame under hydraulic reservoir

One valve on right side of front frame near hoist cylinder ball cap

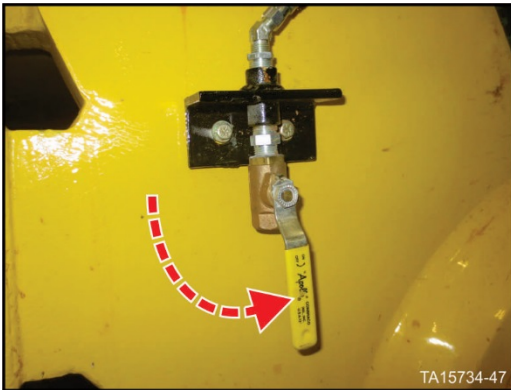

Open air reservoir bleed valves

⚠ WARNING

Crush hazards exist if all personnel are not cleared from the bucket and lift arm area before using the hydraulic hoist and bucket hydraulic pressure bleed down valves to relieve pressure from the hoist and bucket circuit. Assembly must be used only when the engine is NOT running. Before using the Manual Bleed Valve Assembly, refer to “HYDRAULIC AND GREASE SYSTEMS”, “MANUAL BLEED VALVE ASSEMBLY”, in Section 04 of the Service Manual for additional operational and safety information. Operating the manual bleed valve may cause the lift arms and bucket to descend rapidly. All personnel around the bucket and lift arms area shall be removed from the area before operating hydraulic hoist and bucket hydraulic pressure bleed down valves. Using the hydraulic bleed down valves could result in movement of the lift arms and bucket which could cause a crush hazard resulting serious injury or death.

- j. Use the hydraulic pressure bleed down valves located in the front frame underneath the Husco valves to bleed any stored pressure in the hoist and bucket cylinders.
- k. Turn each valve slowly counterclockwise as shown below and allow the pressure to bleed down.
 - Open the valve completely and leave it open during this procedure.

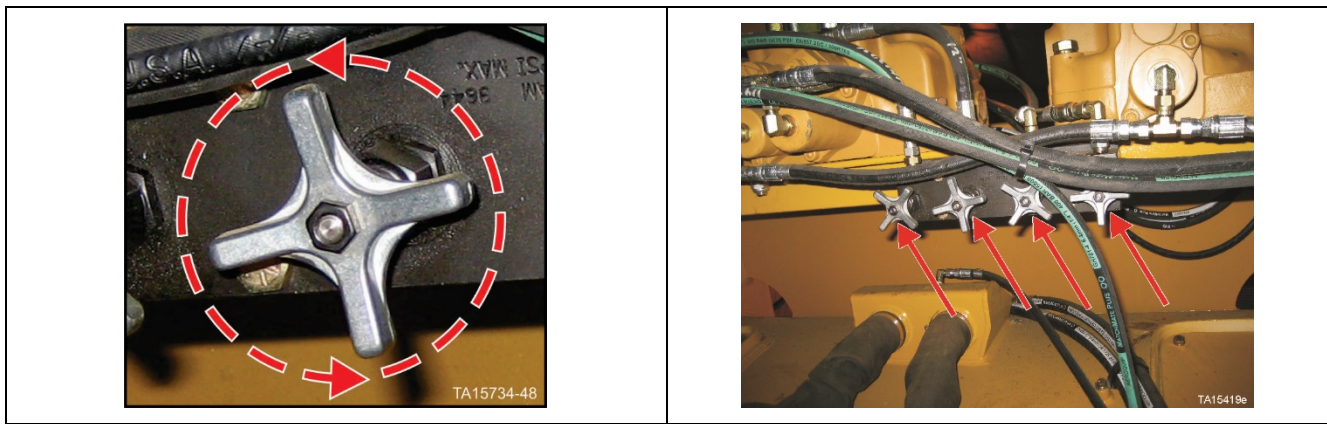

Pressure bleed down valves

- a. Disconnect power supply to the heater.
- b. Remove the strain relief and cap.
- c. Disconnect the leads to the element.
- d. Remove the retaining ring that holds the element in the well.
- e. Pull the old element out of the well and insert the new element.
- f. Replace the retaining ring.
- g. Connect the cord to the element.
- h. Reassemble the cap and strain relief.
- i. Follow all lockout tag out rules, local rules, and local regulations to return the machine back to service.

Replacement of Lube Sensing Unit (if so equipped)

Safety Preparations

WARNING

Crush hazards exist if the machine is started or moved while work processes are being performed on the machine. Place bucket flat and level on the ground. Place frame lock in the locked position and lock out the machine's starting capability before performing any work process. Follow all applicable lockout procedures and local rules and regulations for performing work processes. ANYONE performing inspections or service procedures to the machine should be familiar with ALL instructions and procedures contained in the machine's SERVICE MANUAL. Crush hazard could occur if the machine is started or moves while any type of work process is being conducted on the machine, resulting in serious injury or death.

- a. Stop the wheel loader on flat level ground.
- b. Set bucket flat and level on the ground.

- c. Move the frame lock to the locked position so that the frame cannot be steered.
- d. Place wheel chocks in front and behind each wheel.

WARNING

Crush hazards exist in machine pivot area and area between the tires. Do not enter these areas unless it is verified that the operator has control over the steering and that personnel locking the frame lock have good communication with the operator. Entering the pivot area and area between the tires while the machine is moving or pivoting (articulating) could cause crush hazards resulting in serious injury or death.

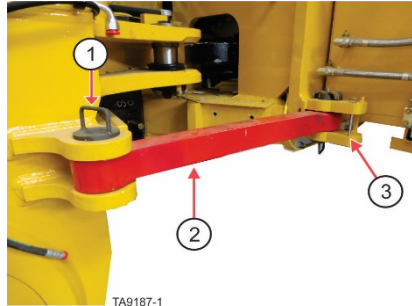

- 1) Retaining pin for locked position, 2) Frame lock - shown in locked position,
- 3) Retaining pin bracket for un-locked position

Frame lock in locked position

- e. Set the parking brakes.
- f. Shut off the engine.

WARNING

Crush, shock, or other hazards exist if stored energy is not removed or isolated prior to working on the machine. Stored energy (hydraulic, electrical, pneumatic, mechanical, etc.) may be present if not isolated or released prior to working on the machine. Do not work on the machine without removing this stored energy (suspended loads, electrical power, air pressure, etc.). Risk of crushing, shock, or other physical injury exists if stored energy is not removed or isolated prior to working on the machine which could result in serious injury or death.

- g. Turn the battery and engine isolation switches to the off position and install locks on the battery isolation switch.



Battery Isolation Box – Battery isolation switch in OFF position with locks in place

- h. Release the air from the hydraulic reservoir by using the hydraulic reservoir air valve (ball valve) on top of the reservoir. The supply line from main air system will be blocked and reservoir air will vent out the hose that runs down the outside of the hydraulic reservoir.
 - Turn the handle to the up position as shown

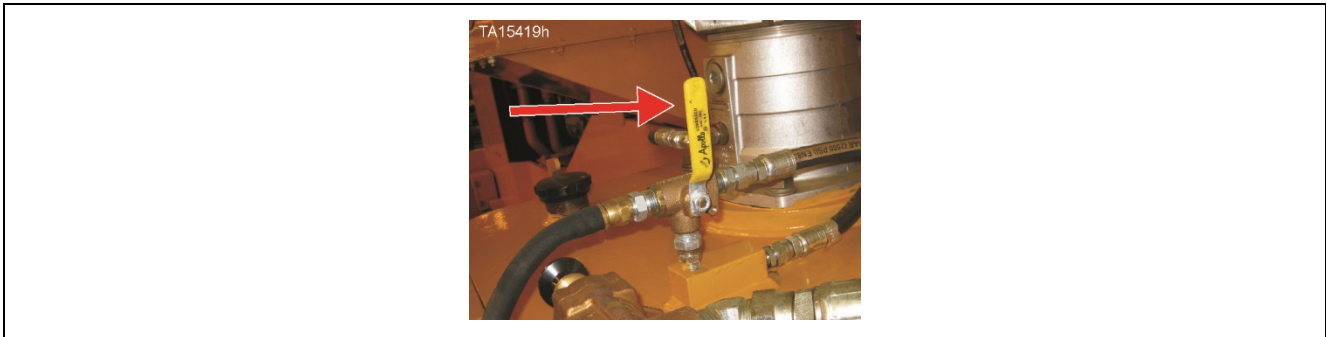

Hydraulic reservoir air valve handle UP

- i. Release the air from the various air storage reservoirs by opening all of the air bleed valves.

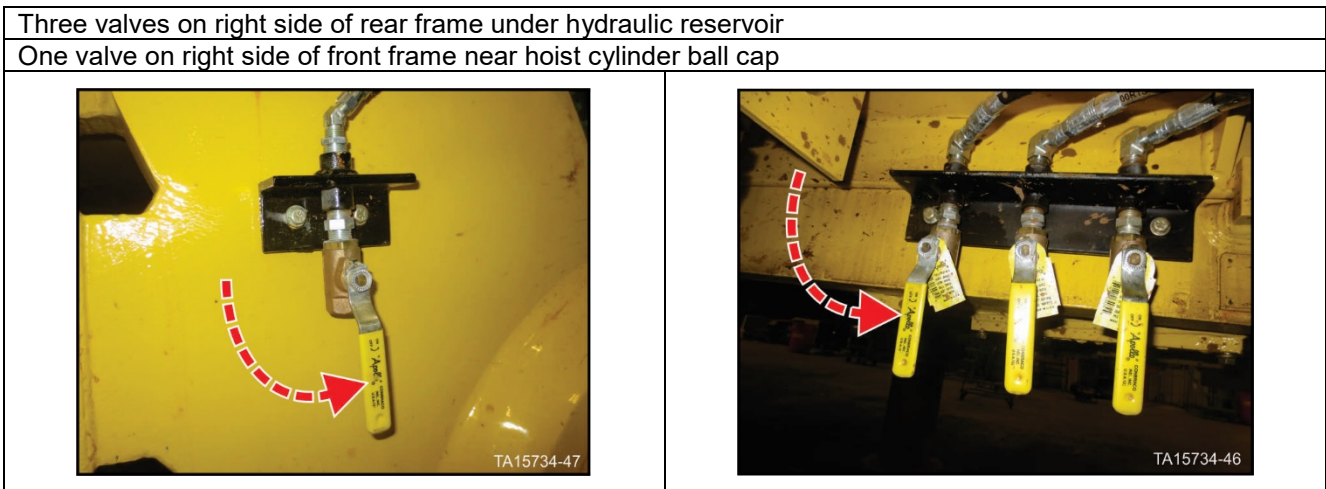

Open air reservoir bleed valves

⚠ WARNING

Crush hazards exist if all personnel are not cleared from the bucket and lift arm area before using the hydraulic hoist and bucket hydraulic pressure bleed down valves to relieve pressure from the hoist and bucket circuit. Assembly must be used only when the engine is NOT running. Before using the Manual Bleed Valve Assembly, refer to “HYDRAULIC AND GREASE SYSTEMS”, “MANUAL BLEED VALVE ASSEMBLY”, in Section 04 of the Service Manual for additional operational and safety information. Operating the manual bleed valve may cause the lift arms and bucket to descend rapidly. All personnel around the bucket and lift arms area shall be removed from the area before operating hydraulic hoist and bucket hydraulic pressure bleed down valves. Using the hydraulic bleed down valves could result in movement of the lift arms and bucket which could cause a crush hazard resulting serious injury or death.

- j. Use the hydraulic pressure bleed down valves located in the front frame underneath the Husco valves to bleed any stored pressure in the hoist and bucket cylinders.
- k. Turn each valve slowly counterclockwise as shown below and allow the pressure to bleed down.
 - Open the valve completely and leave it open during this procedure.

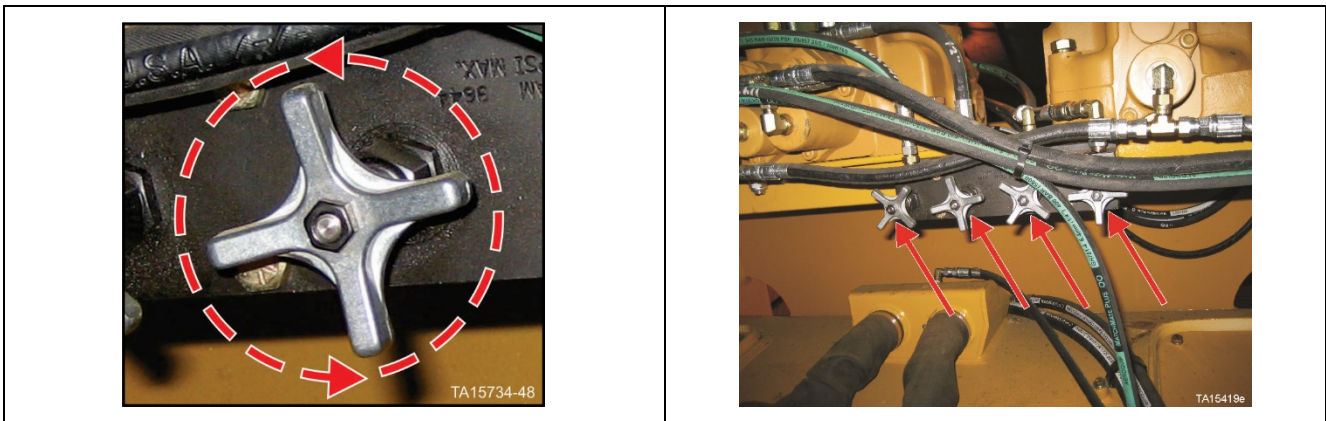

Pressure bleed down valves

- l. Unscrew the hex cap. Pull the cord and sensing unit out of the well.
- m. Pull sensing unit off the cord plug.
- n. Insert new sensing unit into cord. Spade terminals should not be exposed.
- o. Insert the sensing unit and cord into the well, and screw the hex cap down snug. Do not over-tighten.
- p. Follow all lockout tag out rules, local rules, and local regulations to return the machine back to service.

NOTICE

It is not necessary to drain the sump oil to change the heating element or lube-sensing unit.

Settings and Adjustments

Hydraulic Reservoir Heater Setting

Safety Preparations

WARNING

Crush hazards exist if the machine is started or moved while work processes are being performed on the machine. Place bucket flat and level on the ground. Place frame lock in the locked position and lock out the machine's starting capability before performing any work process. Follow all applicable lockout procedures and local rules and regulations for performing work processes. ANYONE performing inspections or service procedures to the machine should be familiar with ALL instructions and procedures contained in the machine's SERVICE MANUAL. Crush hazard could occur if the machine is started or moves while any type of work process is being conducted on the machine, resulting in serious injury or death.

- a. Stop the wheel loader on flat level ground.
- b. Set bucket flat and level on the ground.
- c. Move the frame lock to the locked position so that the frame cannot be steered.
- d. Place wheel chocks in front and behind each wheel.

WARNING

Crush hazards exist in machine pivot area and area between the tires. Do not enter these areas unless it is verified that the operator has control over the steering and that personnel locking the frame lock have good communication with the operator. Entering the pivot area and area between the tires while the machine is moving or pivoting (articulating) could cause crush hazards resulting in serious injury or death.

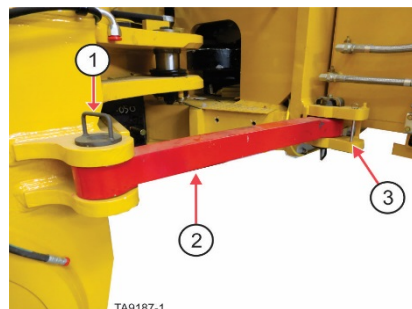

- 1) Retaining pin for locked position, 2) Frame lock - shown in locked position,
- 3) Retaining pin bracket for un-locked position

Frame lock in locked position

- e. Set the parking brakes.
- f. Shut off the engine.

⚠ WARNING

Crush, shock, or other hazards exist if stored energy is not removed or isolated prior to working on the machine. Stored energy (hydraulic, electrical, pneumatic, mechanical, etc.) may be present if not isolated or released prior to working on the machine. Do not work on the machine without removing this stored energy (suspended loads, electrical power, air pressure, etc.). Risk of crushing, shock, or other physical injury exists if stored energy is not removed or isolated prior to working on the machine which could result in serious injury or death.

- g. Turn the battery and engine isolation switches to the off position and install locks on the battery isolation switch.



Battery Isolation Box – Battery isolation switch in OFF position with locks in place

- h. Release the air from the hydraulic reservoir by using the hydraulic reservoir air valve (ball valve) on top of the reservoir. The supply line from main air system will be blocked and reservoir air will vent out the hose that runs down the outside of the hydraulic reservoir.
 - Turn the handle to the up position as shown

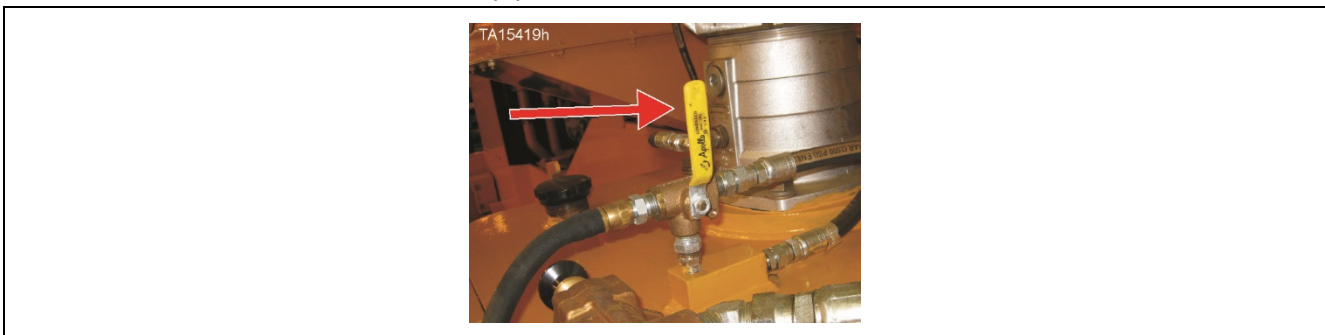

Hydraulic reservoir air valve handle UP

- i. Release the air from the various air storage reservoirs by opening all of the air bleed valves.

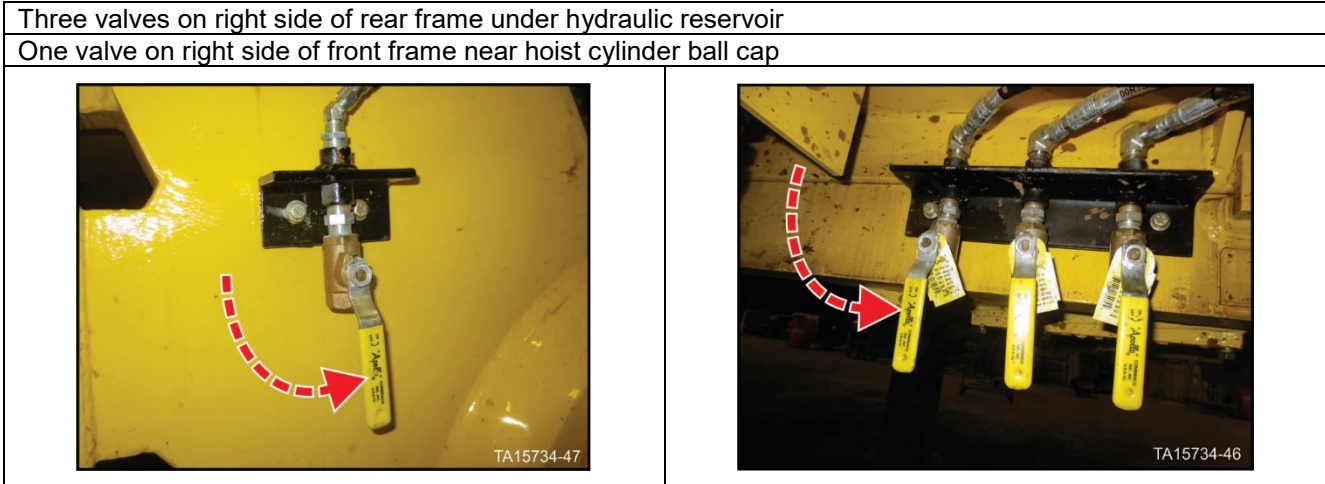

Open air reservoir bleed valves

⚠ WARNING

Crush hazards exist if all personnel are not cleared from the bucket and lift arm area before using the hydraulic hoist and bucket hydraulic pressure bleed down valves to relieve pressure from the hoist and bucket circuit. Assembly must be used only when the engine is NOT running. Before using the Manual Bleed Valve Assembly, refer to “HYDRAULIC AND GREASE SYSTEMS”, “MANUAL BLEED VALVE ASSEMBLY”, in Section 04 of the Service Manual for additional operational and safety information. Operating the manual bleed valve may cause the lift arms and bucket to descend rapidly. All personnel around the bucket and lift arms area shall be removed from the area before operating hydraulic hoist and bucket hydraulic pressure bleed down valves. Using the hydraulic bleed down valves could result in movement of the lift arms and bucket which could cause a crush hazard resulting serious injury or death.

- j. Use the hydraulic pressure bleed down valves located in the front frame underneath the Husco valves to bleed any stored pressure in the hoist and bucket cylinders.
- k. Turn each valve slowly counterclockwise as shown below and allow the pressure to bleed down.
 - Open the valve completely and leave it open during this procedure.

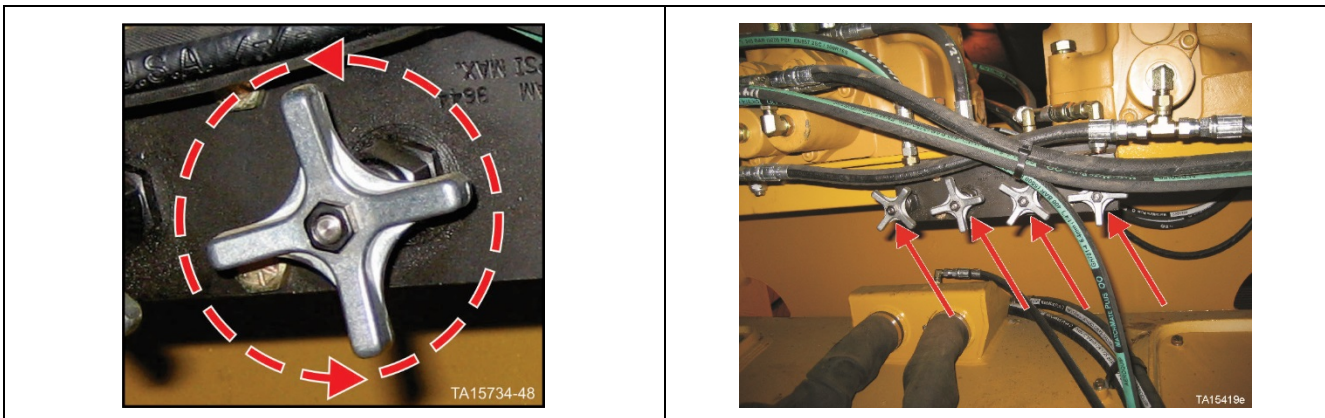

Pressure bleed down valves

- a. The set point is set at the factory at 120° F (49° C).

- b. To adjust the temperature, unscrew the heater cover and turn the thermostat dial to the desired temperature.
- c. Replace the heater cover when finished. Tighten the cover until securely engaging the O-ring seal.

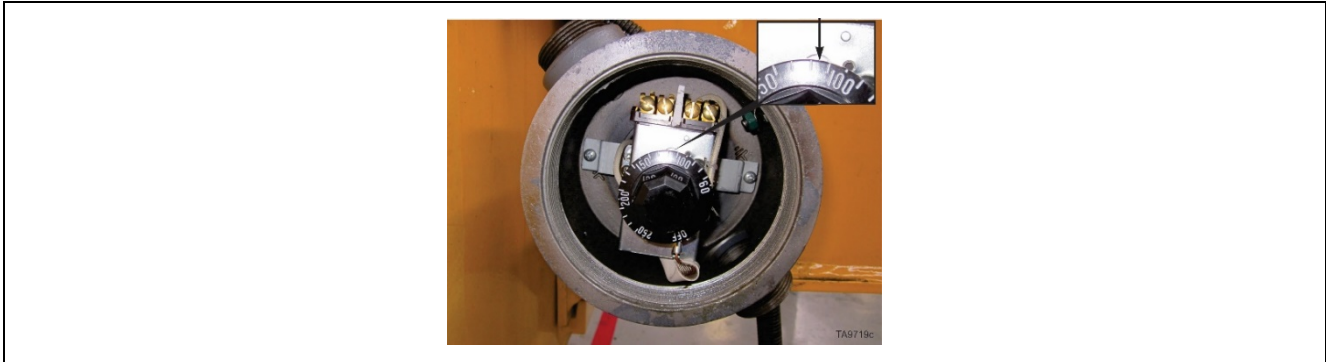

Figure 12. Hydraulic reservoir heater control (shown with cap removed for clarity)

Battery Warmer Setting

CAUTION

The battery warmers do not have a thermostat. They should not be left ON during warm temperatures. Equipment damage is possible.

Grease Reservoir Heater Setting

The grease reservoir heater can be manually set. It has a dial mounted on the reservoir blanket and can be adjusted to the desired temperature. The temperature setting range is 70°F to 425°F (24°C to 218°C).



Figure 13. Grease reservoir heater (thermostat called out)

CAUTION

- The heater must not be clamped in dented areas of the drum.
- The heater must be in full contact with the drum and below the level of liquid while in operation.
- Do not bend the heater sharply as this may cause internal damage to the heating element.
- The drum must be vented to allow for expansion when heating.
- Do not put insulation on the outside of the blanket.

Engine Coolant and Oil Preheater System

These devices are controlled by a single thermostat internal to the system.

This Page Intentionally Left Blank

Troubleshooting

WARNING



Electrical shock hazard exists when working on component heaters. Some heaters may operate as high as 240 volts. Heaters should never be worked on, replaced, or repaired unless they are disconnected from the power source and disabled from operation. Electrical shock is possible. Failure to disconnect equipment before working on it can cause electrical shock hazards resulting in serious injury or death.

The following heaters operate ONLY on external power (a power source that is connected external to the machine).

- Grease Reservoir heater
- Hydraulic Reservoir heater
- Battery Warmer
- Engine Coolant Heater
- Engine Oil Heater

Before testing any individual components:

- Check to be sure that the external power source is providing the correct voltage.
- Check for damaged wiring between the power source connection and the component.

Typically, the heaters can be electrically checked. Refer to vendor information for troubleshooting info for various components.

The following component heaters are supplied by the machines 24V electrical system when it is energized. The machine electrical schematic shows the connections and voltage provided to each heater. (refer to Section 05, "COMPRESSED AIR SYSTEM" for more information).

- KLENZ™ Solenoids
- Air Dryer

This Page Intentionally Left Blank